

# **SUPERTRAK**

*TRACK CABLE SYSTEMS  
for flat or round cables*



- 20kg capacity per trolley dependent on hanger configuration
- A choice of steel, brass or plastic trolleys and wheels
- New advanced design jointing sleeve, which eliminates joint misalignment problems, is positive locking, resists vibrations and is easily assembled without tools
- Simple but effective single bolt suspension system
- High quality and performance
- Cost effective
- Available in straight lengths or curved sections, down to 1m in radius
- Available completely in stainless steel, for really aggressive environment

**CONDUCTIX**  
**INSUL 8**

© DELACHAUX GROUP



Certificate No. FM 21334

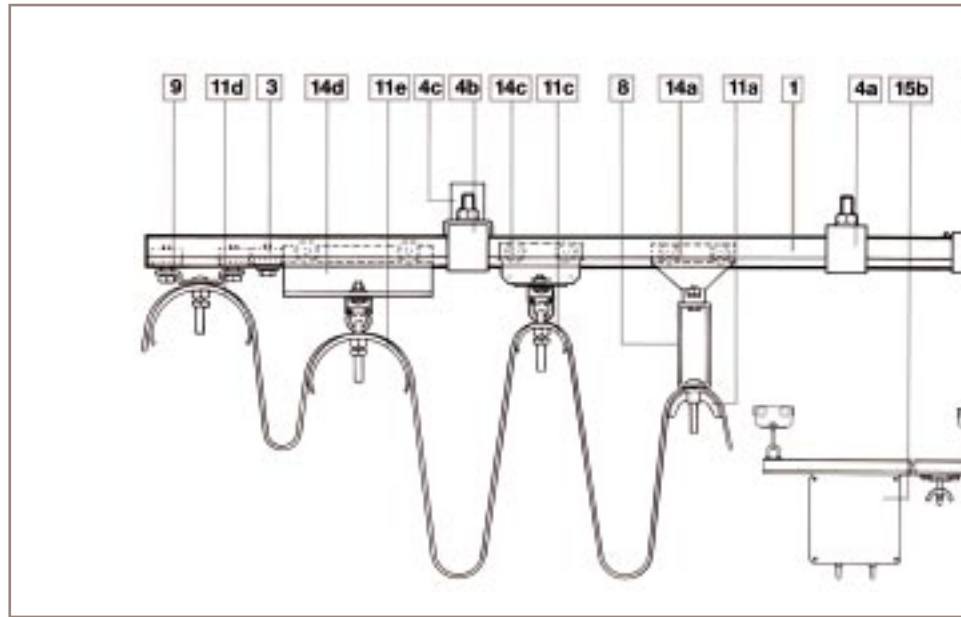

| PART/PART NO. | DIMENSIONS (mm) | DESCRIPTION |
|---------------|-----------------|-------------|
|---------------|-----------------|-------------|

① Track section



No. 2300/3, 3m long. 2300/6, 6m long.

Cold rolled galvanised steel.  
**Weight: 1.11kg/m**  
Available in 3 or 6 metre lengths.

② Joint sleeve



No. 2384

Galvanised steel pressing.  
**Weight: 0.15kg/set**

③ End stop



No. 2102

Plastic moulding with zinc plated steel screw.  
**Weight: 0.05kg**

④a Intermediate top support bracket



No. 2357

Zinc plated and lacquered steel pressing.  
**Weight: 0.14kg**

④b Anchor top support bracket



No. 2358

Zinc plated and lacquered steel pressing.  
**Weight: 0.15kg**

| PART/PART NO. | DIMENSIONS (mm) | DESCRIPTION |
|---------------|-----------------|-------------|
|---------------|-----------------|-------------|

④c Support conversion bracket



No. 2173

Zinc plated steel pressing.  
**Weight: 0.12kg**

④d Anchor suspension top support bracket



No. 2360

Plastic block moulding. Zinc plated and lacquered steel pressing and bolts.  
**Weight: 0.20kg**

④e Intermediate suspension top support bracket



No. 2359

Plastic block moulding. Zinc plated and lacquered steel pressing and bolts.  
**Weight: 0.19kg**

⑤a Suspension bracket



No. 2305

Galvanised steel.  
**Weight: 1.11kg**









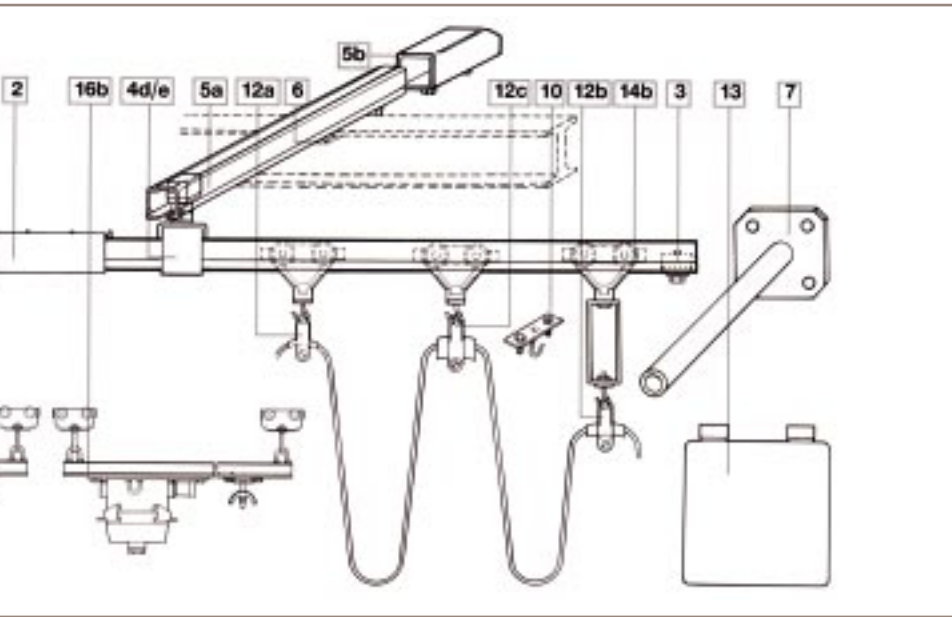

⑤b Suspension bracket support

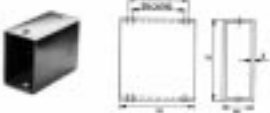







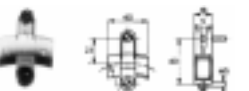
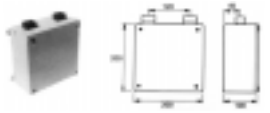
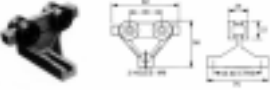
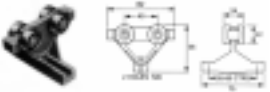

No. 2391

Black steel tube with zinc plated screws.  
**Weight: 0.29kg**

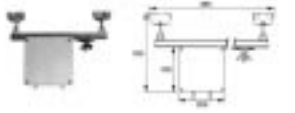
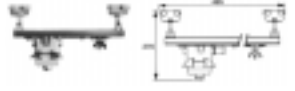

| PART/PART NO.  | DIMENSIONS (mm) | DESCRIPTION   |
|--|-----------------|---|
| <b>6</b> Girder clamp<br><br>No. 2106   |                 | Plastic block moulding. Zinc plated steel pressing.<br><b>Weight: 0.12kg</b>  |
| <b>7</b> Towing arm<br><br>No. 1142   |                 | Zinc plated steel fabrication.<br><b>Weight: 0.50kg</b>   |
| <b>8</b> Tow socket<br><br>No. 2141   |                 | Aluminium with zinc plated steel screws.<br><b>Weight: 0.17kg</b>   |
| <b>9</b> End anchor<br><br>No. 2151   |                 | Aluminium with zinc plated steel screws in plastic block mouldings.<br><b>Weight: 0.10kg</b>                                |
| <b>10</b> Round cable trolley adaptor<br><br>No. 2352   |                 | Zinc plated steel<br><b>Weight: 0.045kg</b><br>(for use with part nos. 2311 and 2312 only)                                  |
| <b>11a</b> Cable former 25 x 74 for use with cables up to 4mm <sup>2</sup><br><br>No. 2321   |                 | Plastic former with zinc plated steel screws.<br><b>Weight: 0.10kg</b><br>(for use with part nos. 2311, 2312 and 2319 only) |
| <b>11b</b> Cable former 25 x 76 for use with cables up to 4mm <sup>2</sup><br><br>No. 2123   |                 | Aluminium former with zinc plated steel screws.<br><b>Weight: 0.05kg</b><br>(for use with part no. 2381 only)               |
| <b>11c</b> Cable former 25 x 130 for use with cables up to 4mm <sup>2</sup><br><br>No. 2131  |                 | Aluminium former with zinc plated steel screws.<br><b>Weight: 0.24kg</b>  |
| <b>11d</b> Cable former 50 x 76 for use with cables up to 25mm <sup>2</sup><br><br>No. 2125  |                 | Aluminium former with zinc plated steel screws.<br><b>Weight: 0.12kg</b><br>(for use with part no. 2381 only)               |
| <b>11e</b> Cable former 50 x 130 for use with cables up to 25mm <sup>2</sup><br><br>No. 2132 |                 | Aluminium former with zinc plated steel screws.<br><b>Weight: 0.37kg</b>  |

| PART/PART NO.   | DIMENSIONS (mm)                                   | DESCRIPTION  |
|---|---|--|
| <b>12a</b> Cable former 5-9mm dia.  |   | Plastic former with zinc plated steel screws.<br><b>Weight: 0.01kg</b>           |
|    |   |  |
| No. 1131  |   |  |
| <b>12b</b> Cable former 10-14mm dia.  |   | Plastic former with zinc plated steel screws.<br><b>Weight: 0.01kg</b>           |
|    |   |  |
| No. 1132  |   |  |
| <b>12c</b> Cable former 15-19mm dia.  |   | Plastic former with zinc plated steel screws.<br><b>Weight: 0.02kg</b>           |
|    |   |  |
| No. 1133  | (for larger round cable formers, contact factory) |  |
| <b>13</b> Connection box  |   | Enamel finish steel box with zinc plated steel fittings<br><b>Weight: 2.11kg</b> |
|   |   |  |
| No. 2162  | (terminal not included)                           |  |
| <b>14a</b> Trolley 82N  |   | Plastic body with plastic wheels and axles.<br><b>Weight: 0.04kg</b>             |
|  |   |  |
| No. 2311  |   |  |
| <b>14b</b> Trolley 82S  |   | Plastic body with zinc plated steel wheels and axles.<br><b>Weight: 0.08kg</b>   |
|  |   |  |
| No. 2312  |   |  |

| PART/PART NO.  | DIMENSIONS (mm) | DESCRIPTION  |
|--|-----------------|--|
| <b>14c</b> Trolley 82S   |                 | Zinc plated and lacquered steel body with zinc plated steel wheels and axles.<br><b>Weight: 0.27kg</b>       |
|    |                 |  |
| No. 2319   |                 |  |
| <b>14d</b> Trolley 160S  |                 | Aluminium body with zinc plated steel wheels and axles.<br><b>Weight: 0.29kg</b>                             |
|    |                 |  |
| No. 2381   |                 |  |
| <b>15a</b> Pendant control box   |                 | Enamel finish steel box. Zinc plated steel trolley with zinc plated fittings.<br><b>Weight: 1.94kg</b>       |
|    |                 |  |
| No. 2361   |                 |  |
| <b>15b</b> Pendant control box   |                 | Enamel finish steel box. Zinc plated steel trolley with zinc plated fittings.<br><b>Weight: 3.34kg</b>       |
|   |                 |  |
| No. 2363   |                 |  |
| <b>16a</b> Pendant trolley   |                 | 16 way plug and socket. Zinc plated steel trolleys with zinc plated steel fittings.<br><b>Weight: 2.40kg</b> |
|  |                 |  |
| No. 2366   |                 |  |
| <b>16b</b> Pendant trolley   |                 | 24 way plug and socket. Zinc plated steel trolleys with zinc plated steel fittings.<br><b>Weight: 2.54kg</b> |
|  |                 |  |
| No. 2367   |                 |  |

In addition to this standard range, we design and manufacture systems to meet specific requirements.

In common with most of our range, these products are available from stock.

We also manufacture, supply and install safe conductor bar systems up to 7500 Amps and festoon systems up to 400kg.

Supported by a range of cable reeling drums and slip-ring assemblies.

## UNITED KINGDOM

CONDUCTIX Ltd (Insul-8)

Salford  
Tel: + (44) 161 848 01 61  
Fax: + (44) 161 873 70 17  
info@conductix.co.uk  
www.conductix.co.uk



© DELACHAUX GROUP  
POWER AND DATA TRANSFER