

Insul-8 Mobile Electrification

Cable Reels ♦ Conductor Bar ♦ Festoon ♦ Pendants ♦ Radios ♦ Slip Rings

Solutions From A Single Source

Hevi-Bar II

Conductor Bar Systems

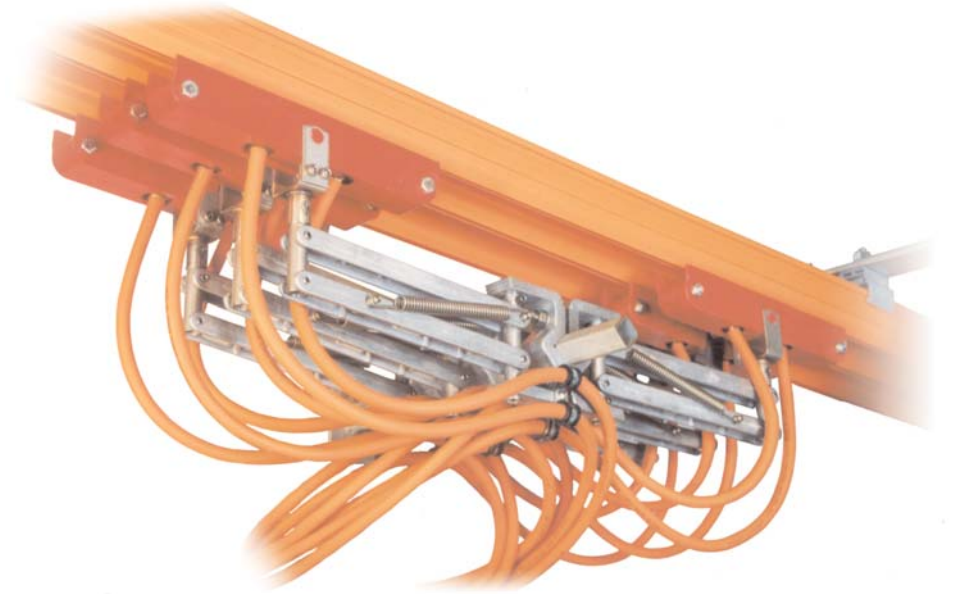

CONDUCTIX
INSUL 8

© DELACHAUX GROUP

www.conductix.us

For the Electrification of:

- Cranes
- Mining Equipment
- Amusement Park Rides / Trams
- People Movers

PROVEN TECHNOLOGY FOR SEVERE APPLICATIONS

Dependable Insul-8 Hevi-Bar II systems efficiently deliver the high-capacity electrical service that is needed in factories, storage yards, people movers and other demanding installations. Its configuration uses surface area rather than mass to dissipate the heat generated by high current conditions. The Hevi-Bar II design also allows for lateral and vertical entry. A choice of insulating covers are available. Hevi-Bar II was designed as a companion of the original Hevi-Bar to provide the most efficient, easy-to-install mobile electrification system in the industry.

Installation References Available By Request

INSUL-8: THE INDUSTRY STANDARD FOR OVER 50 YEARS

- ✓ Customer Service
- ✓ Product Design
- ✓ Engineering Assistance
- ✓ Commitment to Quality
- ✓ Quick and Reliable Deliveries



Hevi-Bar II Components

CONDUCTOR BAR

A long wearing, corrosion-resistant 304 stainless steel contact surface. Insulating covers rated to temperatures of PVC: 75° C (160° F) Medium Heat: 121° (250° F) and, High Heat: 204° C (400° F) of glass filled polyester. Cover is furnished with standard conductor bar lengths.

Amperage	Length	Weight (in lbs.)	Cover	Part #
500	30' Special	25	PVC	27582 27583
700	30' Special	40	PVC	24528 24529
1000	30' Special	79	PVC	23500 23503
1500	30' Special	106	PVC	24000 24003
500	30'	25	Medium Heat	32496
1000	30'	79	Medium Heat	31991
700	30'	42	High Heat	24554
1000	30'	83	High Heat	23508

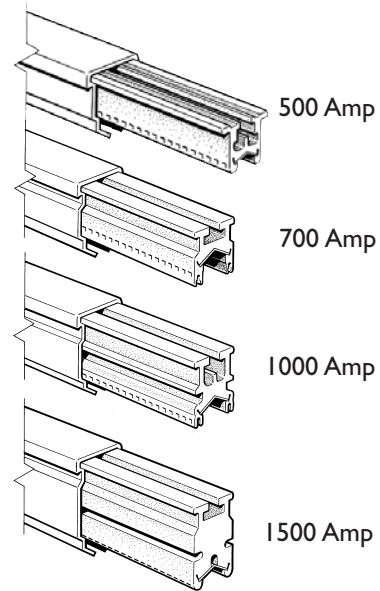

EXPANSION SECTION

Used at all structural expansion joints and for long runways to compensate for thermal expansion.

Amperage	Length	Weight (in lbs.)	Cover	Part #
500	30'	28	PVC	37677
700	20'	45	PVC	24566
1000	20'	65	PVC	23512
1500	20'	85	PVC	32820
500	30'	28	Medium Heat	32498
1000	12'	65	Medium Heat	31963
700	20'	47	High Heat	24567
1000	20'	69	High Heat	23514

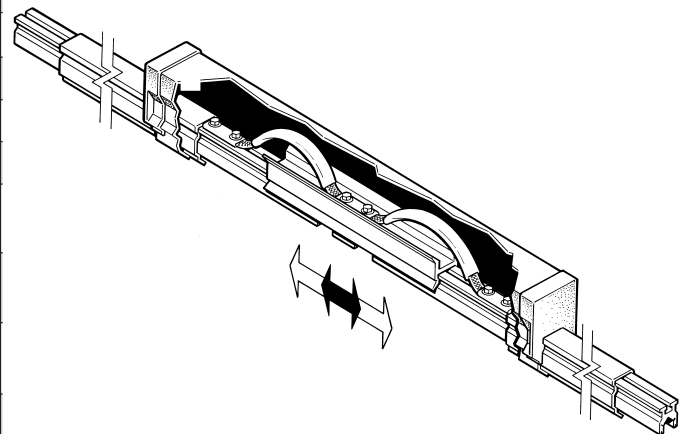

HEVI-BAR II COMPONENTS

POLYCARBONATE SNAP-IN HANGER CLAMP

Provides permanent support without further adjustment. Optional 600 volt insulators are molded fiberglass reinforced polyester and are factory assembled for simple field installation.

(Not for use with High Heat Cover)

Amperage	Weight	Part #
500	.2	26591
700-1500	.2	23223



Amperage	Weight	Part #
500	1.0	27483
700-1500	1.0	24902

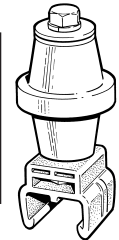

STAINLESS STEEL CROSS-BOLT HANGER CLAMP

Easily installed hangers are used for both anchor-tight and sliding-tight conditions; indoors or outdoors. All clamps are die formed from heavy gauge type 304 stainless steel. Pull-out support is over 500 lbs. Hardware is plated steel. Optional 600 volt insulators are molded fiberglass reinforced polyester and are highly resistant to arching. Factory assembled for simple field installation.

Amperage	Weight	Part #
500	.4	27481
700-1500	.4	25986

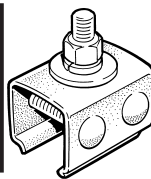

Amperage	Weight	Part #
500	1.25	27482
700-1500	1.25	24973

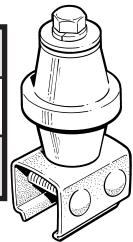

SUPPORT BRACKET ASSEMBLY

Note: Hanger Spacing

500 Amp	5 ft. max.
700 Amp	7.5 ft. max.
1000-1500 Amp.	10.0 ft. max.

Amperage	Weight	Part #
5"Web x 3" Centers (3 Conductor)		
500	5.5	27484
700-1500	5.5	24786
Bracket only part # 24772		
9"Web x 3" Centers (3 Conductor)		
500	6.5	27485
700-1500	6.5	24785
Bracket only part # 24784		
9"Web x 3" Centers (4 Conductor)		
500	6.5	34814B
700-1500	6.5	32932B
Bracket only part # 30503		

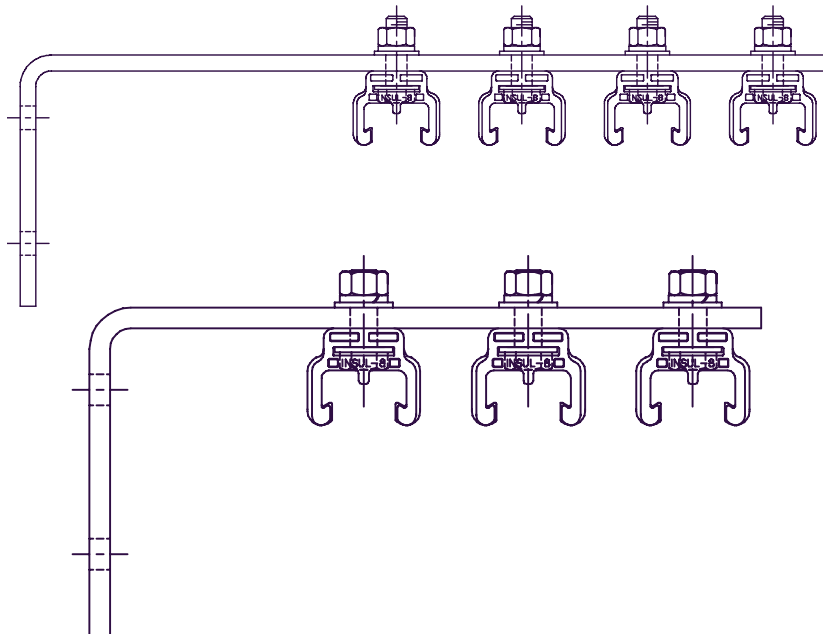

Hevi-Bar II Components

SPLICE ASSEMBLY KIT

These assemblies provide continuous insulation and conductivity. Splices include: aluminum splice bar, bolts, washers, nuts & insulating cover

Amperage	Weight (in lbs.)	Cover	Part #
500	1.5	PVC	37676
700	2.0	PVC	38115
1000	3.0	PVC	38004
1500	4.0	PVC	24028
500	1.5	Medium Heat	32499
1000	3.0	Medium Heat	31964
700	2.5	High Heat	24558
1000	3.5	High Heat	23520

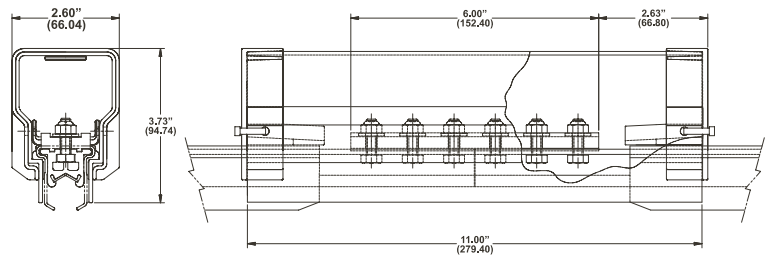

POWERFEED ASSEMBLY KIT(WITH COVER)

This assembly can be bolted on at any location. The cable lug will accept sizes of cables from #2/0 thru 500 MCM.

Amperage	Weight (in lbs.)	Max. Cable Cover	Cover	Part #
500	4.0	350 MCM	PVC	37674
700	3.0	500 MCM	PVC	38117
1000	6.0	500 MCM	PVC	38184
1500	6.0	500 MCM	PVC	24666
500	4.0	350 MCM	Medium Heat	32500
1000	6.0	500 MCM	Medium Heat	38184D
700	3.5	500 MCM	High Heat	24594
1000	6.5	500 MCM	High Heat	23530

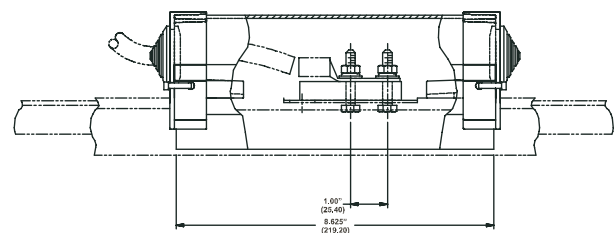
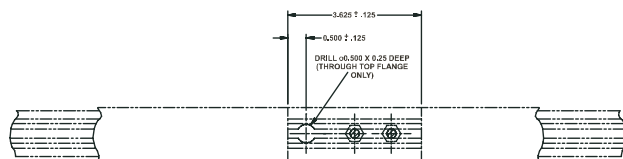
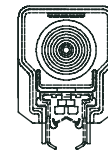

HEVI-BAR II COMPONENTS

END COVER

Cover is used at runway ends to cover exposed conductor.

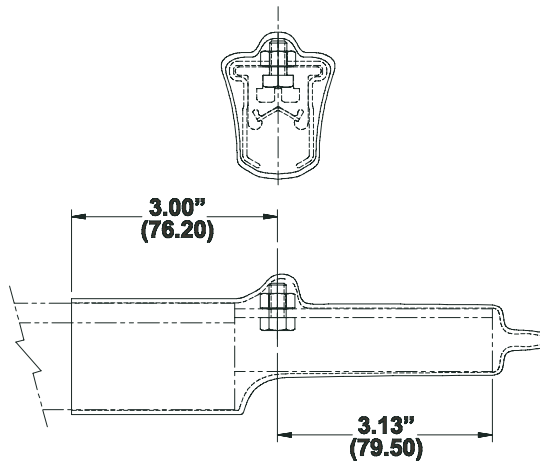

Amperage	Weight (in lbs.)	Cover	Part #
500	1.0	Polyolefin	27588
700	1.0	Polyolefin	33796
1000	1.0	Polyolefin	33796
1500	1.0	Polyolefin	24021
500	1.0	Medium Heat	32501
1000	1.0	Medium Heat	32176
700	1.5	High Heat	24585
1000	1.5	High Heat	23523

ANCHOR PIN SET

Made of glass filled polyester, this piece is field assembled at predetermined locations to hold the conductor solidly. (Set includes two pins)

Amperage	Weight	Part #
All Hevi-Bar II	.2	23946

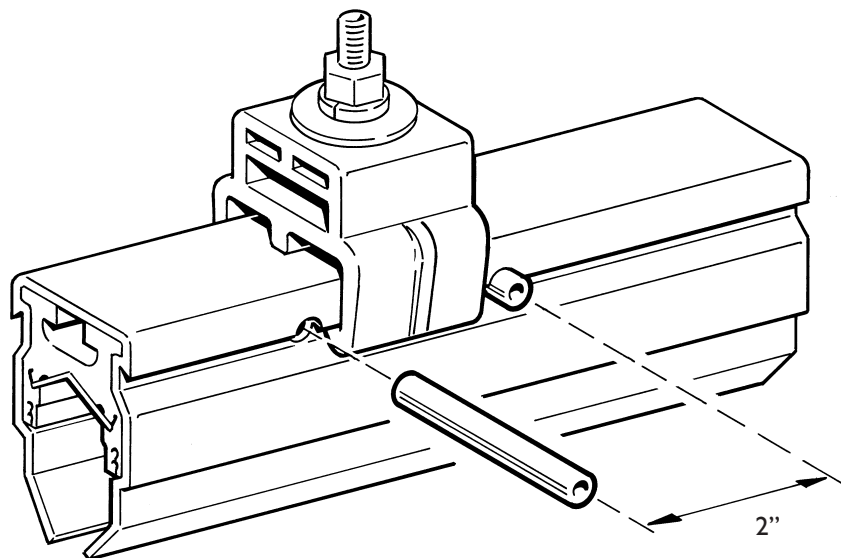

Collectors

These are parallelogram devices which both articulate and swivel. Positive contact with the conductor bar is maintained by spring loaded arms through 5.5" vertical and 5" horizontal travel throughout this working range. Exposed metal parts are stainless steel and aluminum. The replaceable contact shoes are mounted in non-conducting cases. Metal parts are grounded to the collector mounting brackets. Flexible leads are furnished to assure free movement and tracking of the collector shoe.

*Note: Only representative collector versions and part numbers are listed.
Consult factory for other collectors available.*

FOR 500 AMP CONDUCTOR BAR

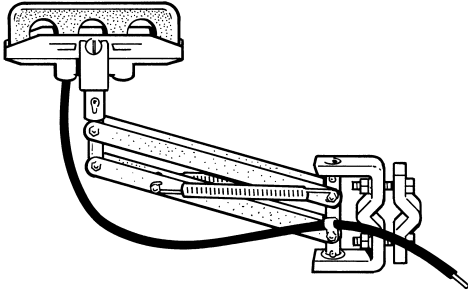

Capacity	Weight	Part #
125 Amp.	5.0	30388

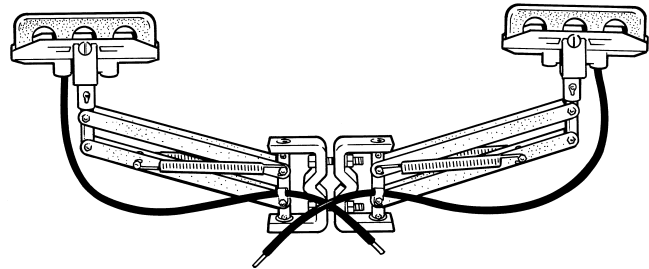

Capacity	Weight	Part #
250 Amp.	10.0	30389

FOR 700, 1000, 1500 AMP CONDUCTOR BAR

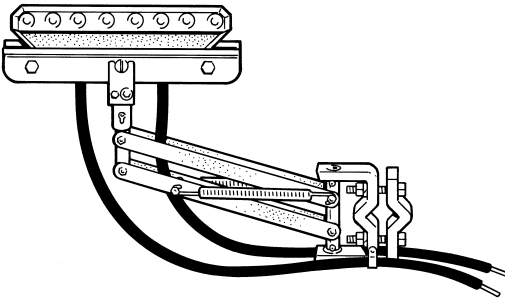

Capacity	Weight	Part #
200 Amp.	6.0	24060

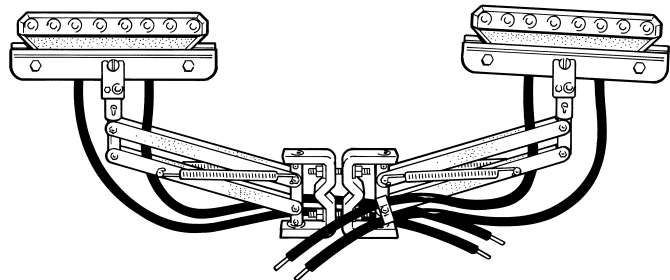

Capacity	Weight	Part #
500 Amp.	12.0	24061

TRANSIT COLLECTOR

*For High Speed Applications Only
Consult Factory for specifications.*

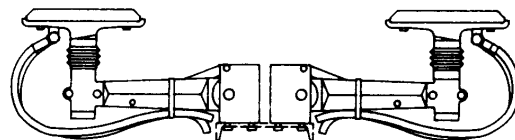

ENGINEERING DATA

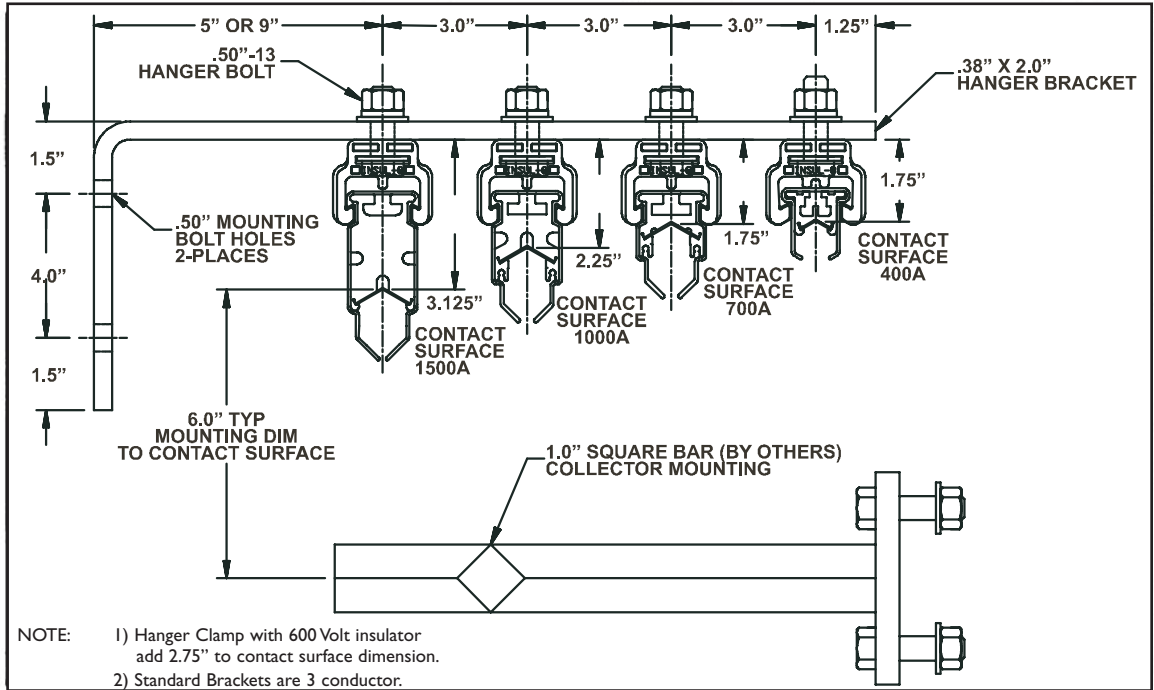

VOLTAGE DROP: "The arithmetical difference between the voltages at the feed point and the load at extreme end." It is usually expressed as a percentage of the supply voltage and can be calculated as shown below.

Voltage drop increases in direct proportion to the length of the conductors. The Electrical Overhead Crane Industry specifications limit total voltage drops to 3% on runways and 2% on bridge conductors. Since powerfeeds are sometimes located at the mid-point of a system, the effective length is the distance from powerfeed to the end of the runway. On longer systems it may be necessary to provide additional feed points.

Conductor	* 3φ 60 Hz	* 3φ 60 Hz	Resistance	Example
Aluminum	3 in.	5 in.	Microhms Per Foot	
500 Amp	.907	1.000	33	700 Amp 3φ 350' long. 250 amp load Vd = .682 x 3.5 x 2.5 = 6.0V Assume load pF is .90
700 Amp	.682	.772	20	
1000 Amp	.532	.621	14	
1500 Amp	.365	.415	6	

*These are voltage drop multipliers per 100 feet per 100 Amps.

50 Hz Multiply by .833.

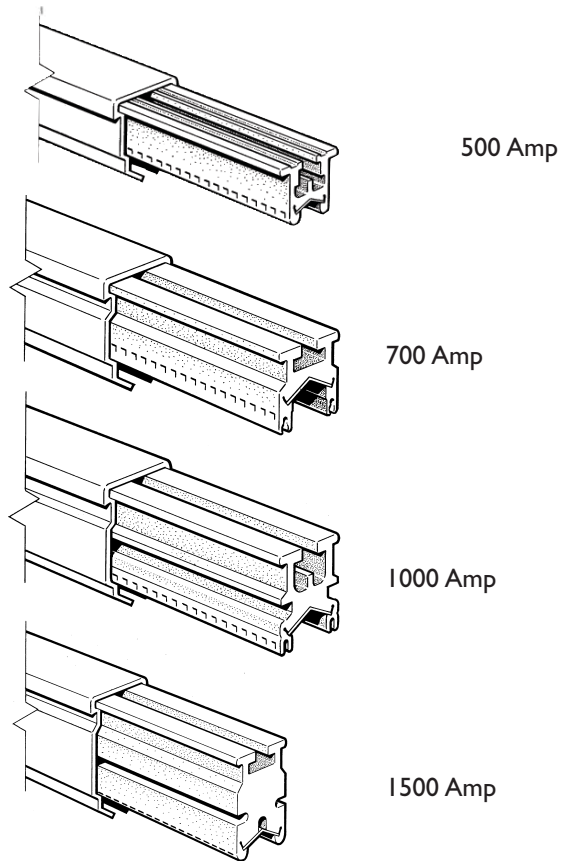

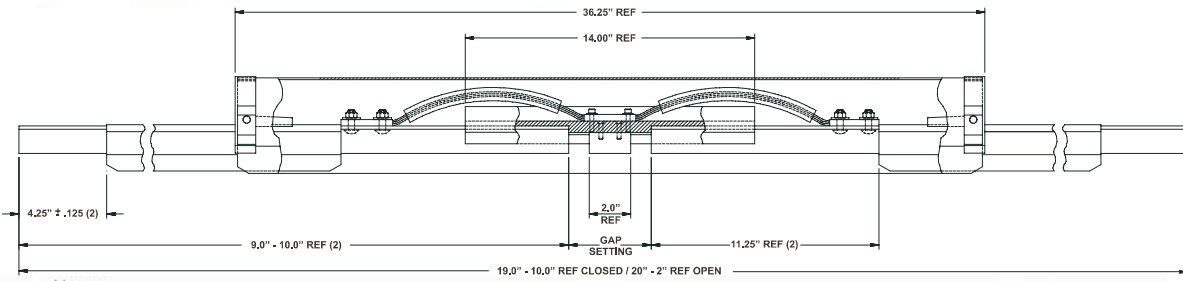

Notes:

1. Consult factory for operating or ambient temperatures beyond the indicated range.
2. All hanger clamps except anchor points must be sliding-tight.

EXAMPLE OF 3 PHASE RUNWAY

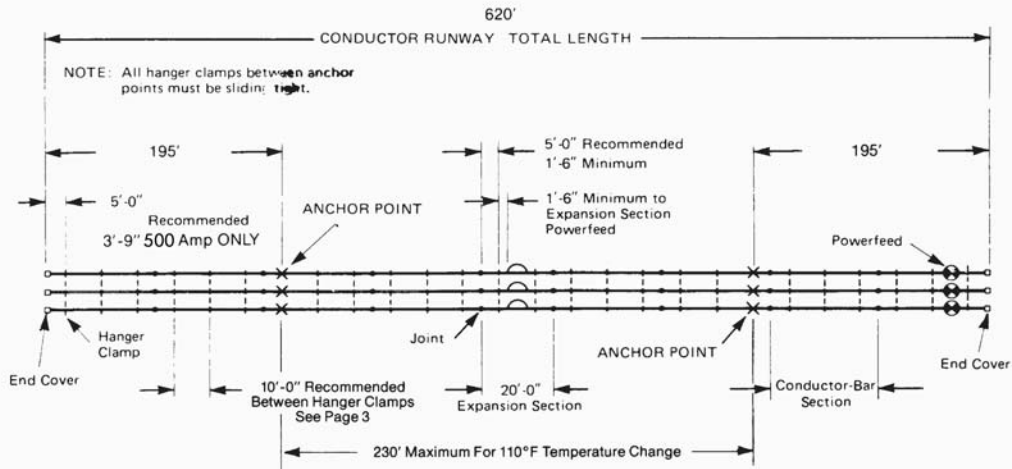

EXPANSION SECTION APPLICATIONS

1. Consideration at structural expansion joints.
2. Use as required by system thermal expansion, based on the standard design conditions of 110°F (61°C) maximum temperature change.
For example, in the above sketch the distance between anchor points is not to exceed 230'. Longer runs or severe ambient conditions will require additional expansion sections. Consult factory.

ANCHOR POINT LOCATIONS

1. Systems without expansion sections: anchor point at center of run only; all others must be sliding-tight.
2. Systems with one expansion section see layout above.
3. Systems with more than one expansion section:
 - a. Anchor point to be midway of each expansion section.
 - b. Anchor point also between last expansion section and end of runway.
4. Anchor Point: Hanger clamp with cross bolts tightened so clamp is rigid with conductor or anchor pins with polycarbonate snap-in hangers.

COMPONENT PARTS

SPLICE ASSEMBLY KIT		
CAPACITY	SPLICE BAR w/HARDWARE	SPLICE COVER
500 Amp.	37676	38015
700 Amp.	38115	38210
1000 Amp.	38004	38238
1500 Amp.	24028	24020

COLLECTORS 30388 & 30389		
DESCRIPTION	WT.	CAT. NO.
Shoe, copper graphite	.9	30516
Case	.1	13210
TRANSIT COLLECTORS		
DESCRIPTION	WT.	CAT. NO.
Shoe, copper graphite	.5	25871

COLLECTORS 24060 & 24061		
DESCRIPTION	WT.	CAT. NO.
Shoe half, copper graphite (pair)	1.0	11417
Shoe half, insuloy (pair)	1.0	20255
Case half	.4	24840

Solutions from a Single Source

ISO 9001 Certified

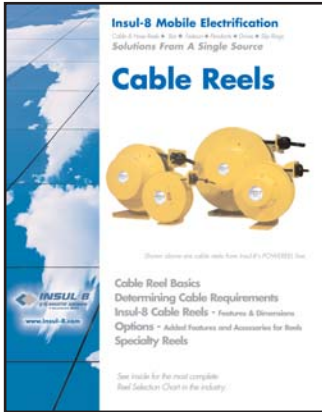

SPRING DRIVEN REELS

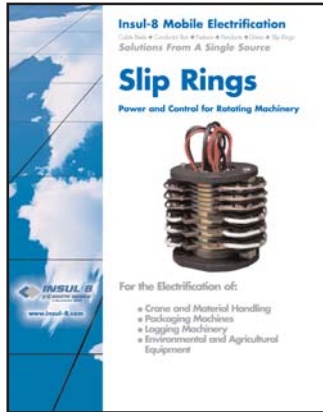

SLIP RINGS

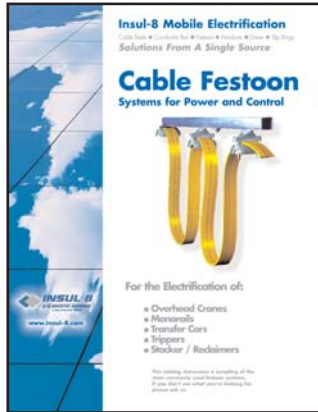

FESTOON

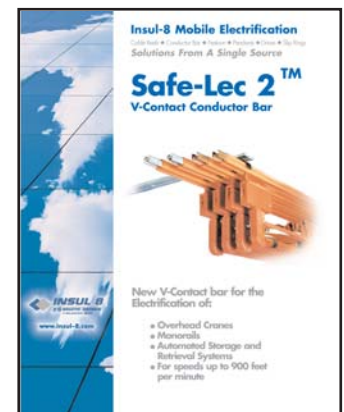

CONDUCTOR BAR

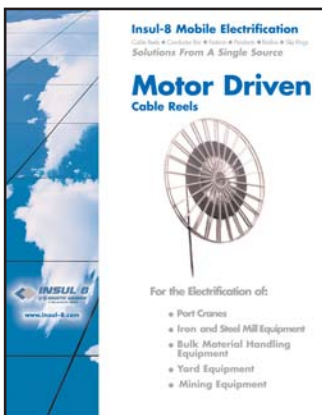

MOTOR DRIVEN REELS



Push-Button Pendant & Radio Controls

Please visit our website at:
www.insul-8.com

CANADA

175 Boulevard J.F. Kennedy
St. Jerome, Quebec J7Y 4B5

Phone: (450) 565-9900
Toll Free: (800) 667-2487
Fax: (450) 432-6985
e-mail: contact@insul-8.com

USA

10102 F Street
Omaha, NE 68127

Phone: (402) 339-9300
Toll Free: (800) 521-4888
Fax: (402) 339-9627
e-mail: i8-info@insul-8.com

AUSTRALIA:

14 England Street
Dandenong, Victoria 3175

Phone: (3) 9706 88 44
Fax: (3) 794 92 98
e-mail: insul8@peninsula.starway.net.au