

# INSUL-8-BAR

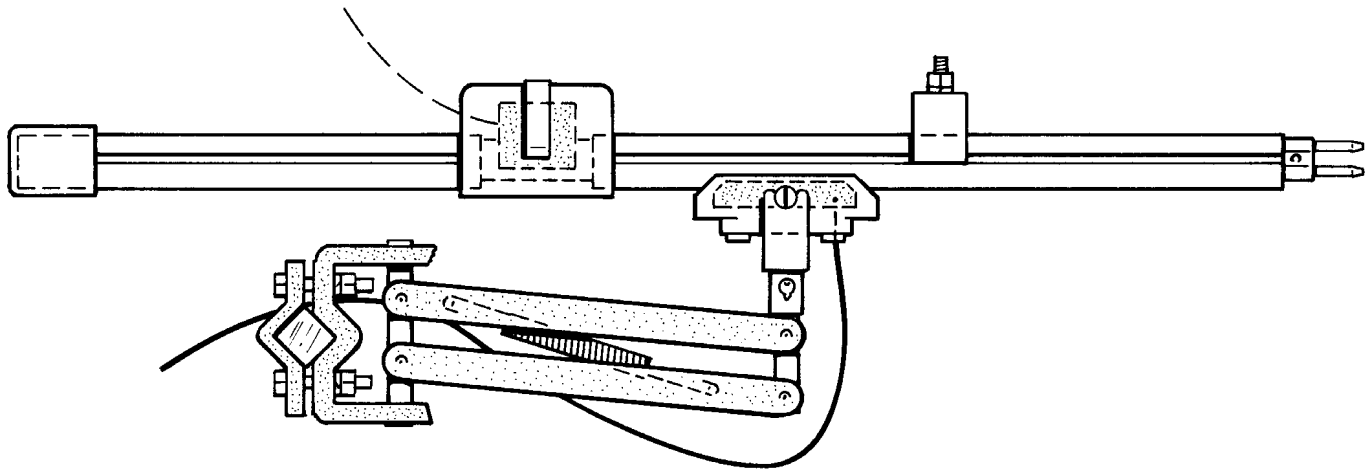

- I. Typical Installations
- II. Layout for Straight Runways
- III. Collector Mounting
- IV. Expansion Gap & Anchoring Requirements
- V. Installation Procedure
  1. Install Hanger & Anchor Clamps as required.
  2. Install Conductor Bar.
  3. Join Conductor Bar.
  4. Install Joint Keepers.
  5. Install Joint Covers.
  6. Install Powerfeeds.
  7. Install End Covers & Transfer Caps.
  8. Install Collectors.
  9. Final Inspection.
- VI. Special Applications
- VII. Troubleshooting
- VIII. Replacement Parts



10102 F Street Omaha, NE 68127-1181 • 402/339-9300 • Fax 402/339-9627  
• USA 800/521-4888 800/334-3283 CANADA •

---

---

## INSUL-8 CORPORATION

The technical data and images which appear in this manual are for informational purposes only. **NO WARRANTIES, EXPRESS OR IMPLIED, INCLUDING WARRANTIES OF MERCHANTABILITY OR FITNESS FOR A PARTICULAR PURPOSE, ARE CREATED BY THE DESCRIPTIONS AND DEPICTIONS OF THE PRODUCTS SHOWN IN THIS MANUAL.** Insul-8 makes no warranty (and assumes no liability) as to function of equipment or operation of systems built according to customer design or of the ability of any of its products to interface, operate or function with any portions of customer systems not provided by Insul-8.

Seller agrees to repair or exchange the goods sold hereunder necessitated by reason of defective workmanship and material discovered and reported to Seller within one year after shipment of such goods to Buyer.

Except where the nature of the defect is such that it is appropriate, in Seller's judgment, to effect repairs on site, Seller's obligation hereunder to remedy defects shall be limited to repairing or replacing (at Seller's option) FOB point of original shipment by Seller, any part returned to Seller at the risk and cost of Buyer. Defective parts replaced by Seller shall become the property of Seller.

Seller shall only be obligated to make such repair or replacement if the goods have been used by Buyer only in service recommended by Seller and altered only as authorized by Seller. Seller is not responsible for defects which arise from improper installation, neglect, or improper use or from normal wear and tear.

Additionally, Seller's obligation shall be limited by the manufacturer's warranty (and is not further warranted by Seller) for all parts procured from others according to published data, specifications or performance information not designed by or for Seller.

Seller further agrees to replace or at Seller's option to provide a refund of the sales price of any goods that do not conform to applicable specifications or which differ from that agreed to be supplied which non-conformity is discovered and forthwith reported to Seller within thirty (30) days after shipment to the Buyer. Seller's obligation to replace or refund the purchase price for non-conforming goods shall arise once Buyer returns such goods FOB point of original shipment by Seller at the risk and cost of Buyer. Goods replaced by Seller shall become the property of Seller.

There is no guarantee or warranty as to anything made or sold by Seller, or any services performed, except as to title and freedom from encumbrances and, except as herein expressly stated and particularly, and without limiting the foregoing, **there is no guarantee or warranty, express or implied, of merchantability or of fitness for any particular purpose or against claim of infringement or the like.**

Seller makes no warranty (and assumes no liability) as to function of equipment or operation of systems built to Buyer's design or of the ability of any goods to interface, operate or function with any portions of Buyer's system not provided by Seller.

Seller's liability on any claim, whether in contract, tort (including negligence), or otherwise, for any loss or damage arising out of, connected with, or resulting from the manufacture, sale, delivery, resale, repair, replacement or use of any products or services shall in no case exceed the price paid for the product or services or any part thereof which give rise to the claim. In no event shall Seller be liable for consequential, special, incidental or other damages, nor shall Seller be liable in respect of personal injury or damage to property not the subject matter hereof unless attributable to gross misconduct of Seller, which shall mean an act or omission by Seller demonstrating reckless disregard of the foreseeable consequences thereof.

Seller is not responsible for incorrect choice of models or where products are used in excess of their rated and recommended capacities and design functions or under abnormal conditions. Seller assumes no liability for loss of time, damage or injuries to property or persons resulting from the use of Seller's products. Buyer shall hold Seller harmless from all liability, claims, suits and expenses in connection with loss or damage resulting from operation of products or utilization of services, respectively, of Seller and shall defend any suit or action which might arise therefrom in Buyer's name - provided that Seller shall have the right to elect to defend any such suit or action for the account of Buyer. The foregoing shall be the exclusive remedies of the Buyer and all persons and entitles claiming through the Buyer.

---

---

# SAFETY

---

## SAFETY WARNINGS

Disconnect Power and follow all lock-out tag-out procedures as described in Appendix A of OSHA Section 1910.147.

All personnel must practice strict adherence to both local and national safety procedures, codes, regulations, and ordinances.

All personnel installing a power rail system should be familiar with the layout details and the component locations.

**Warning:** The law recognizes that electrical energy as commonly utilized in industrial and transit operations is dangerous and capable of causing serious damage, injury or death. Requirements governing the handling and use of electricity, some general and some very specific and detailed, are found in various statutes like the **Workmen's Compensation Acts, Employer's Liability Acts, National Electrical Safety Code** (U.S. Dept. of Commerce), **Occupational Safety and Health Administration** (OSHA), etc. and city or local ordinances. When using electrical power, the law imposes the general obligation to use care to protect against accidental injury or damage to properties.

---

---

# INSTALLATION

---

## GENERAL NOTES

### Required Hand Tools

Torque Wrench  
Socket Wrench Set  
Small Ball Peen Hammer  
Hacksaw  
Screwdriver Set  
3/8" Drill & Drill Bit Set  
Small File Set

### All Installations

Conductor Bar should be stored overnight in the installation environment to assure that all bar has equalized to the ambient air temperature. The bar must be installed with a relatively uniform temperature to allow proper gaging of the expansion section gap setting.

### Standard Mounting

Insul-8-Bar is typically installed with bar profile oriented vertically and the collector shoe entering from the bottom.

Installations that operate in a wet or dirty atmosphere or corrosive environment must be vertically mounted.

### Lateral Mounting

Some installations require the collector shoe to enter from the side. Insul-8-Bar can be adapted to this configuration when required. Consult the factory for further assistance.

### Nomenclature

**Anchor Tight:** The clamping force required to overcome movement due to the heating and cooling of the conductor bar.

**Sliding Tight:** The clamping force required to hold the bar in place while allowing movement due to the heating and cooling of the conductor bar. Plastic and Steel Snap-In Hangers are both designed to provide a sliding tight fit.

All conductor bar that is not specified to be anchor tight must be installed sliding tight to assure reliable operation.

### Additional Information

Any questions regarding the installation or use of Insul-8-Bar that are not addressed in this manual can be answered by Insul-8 Engineering.

Contact the factory: **800-521-4888**

# I. Typical Installations

## A. Standard Vertical Mounting Web Brackets

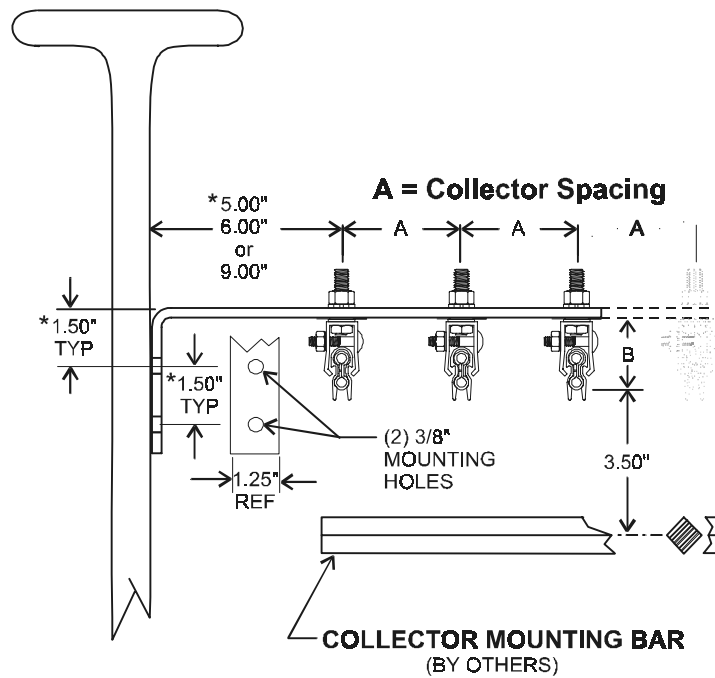

### "A" - Hanger/Conductor Bar Spacing

- 3" Recommended
- 2" Minimum (Collectors Adjacent).
- 1-1/2" Minimum (Collectors Staggered).
- 3" or 4" when Pickup Guides are used.
- 2" Minimum in systems with curves.
- 2" Minimum (Insulated Hangers).

### "B" - Support to Contact Surface

- 1-3/4" Plastic Snap-In, Cross-Bolt and Anchor Clamp w/ Spacer.
- 1-3/8" Steel Snap-In and Anchor w/o Spacer.

\*\* For Hangers with Insulators  
Add 1" to above dimensions.

\*Note: Mounting Dimensions Depend on Bracket used in Installation.

## B. Standard Monorail/Underhung Crane Application - Flange Brackets

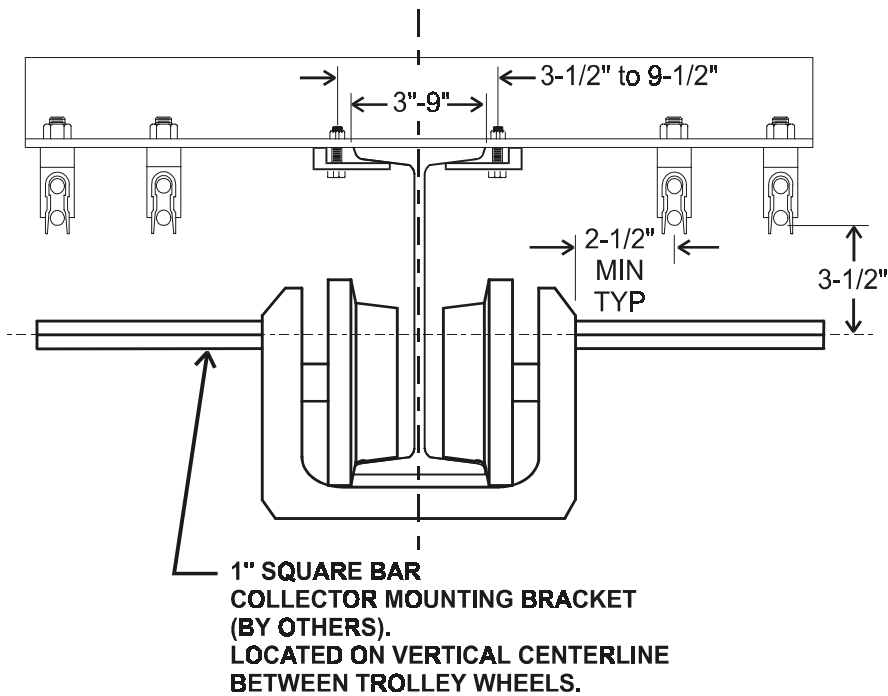

## C. Lateral Mounting.

(Not Recommended for wet or dirty environments.)

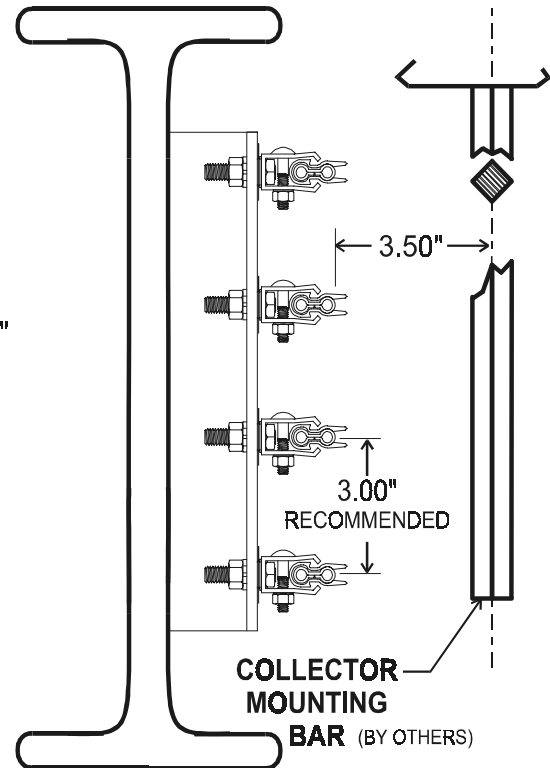

## Plastic Snap-In Hanger Clamps

(Not recommended for lateral mount or curves)

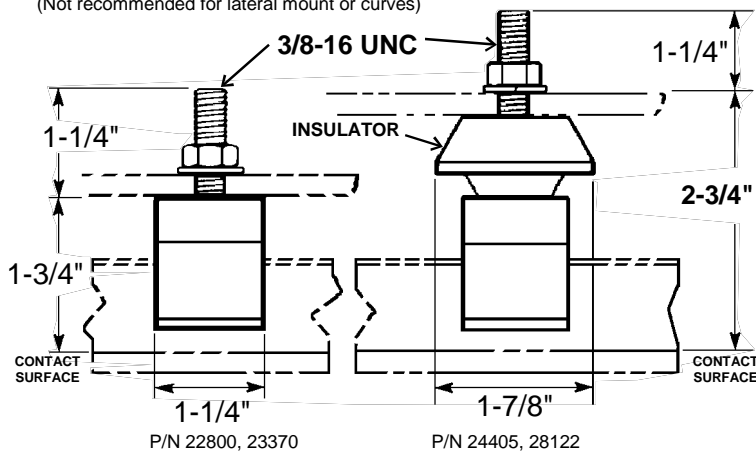

## Steel Snap-In Hanger Clamps

(Not recommended for lateral mount or curves)

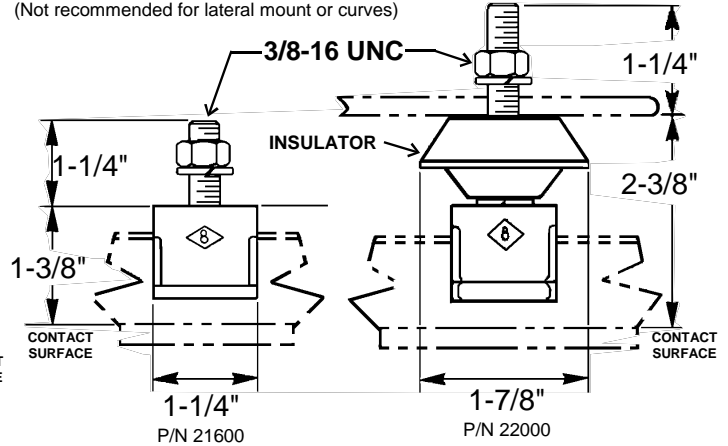

## Cross-Bolt Hanger Clamps

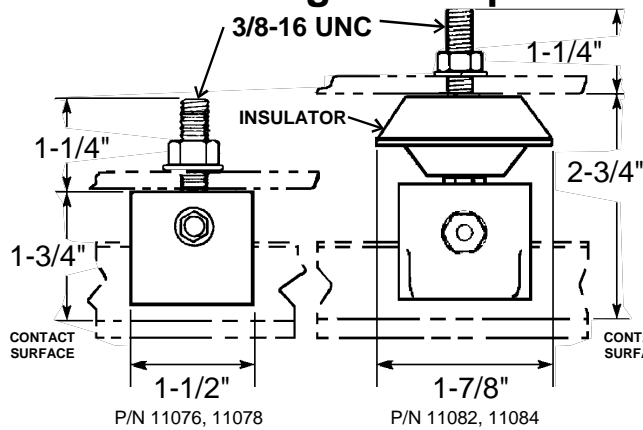

## Anchor Clamps

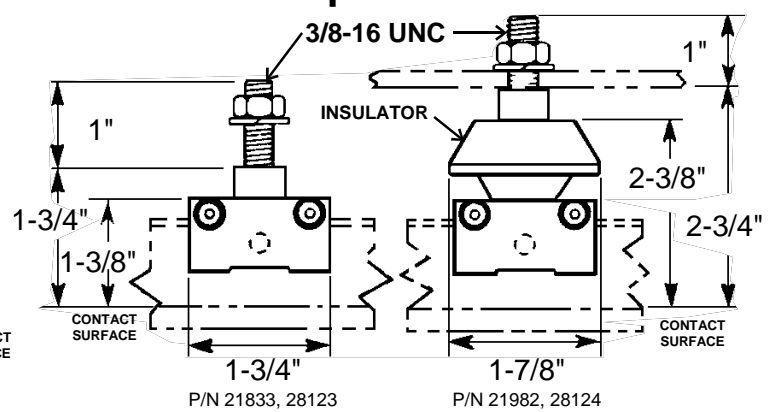

## II. Typical Layout for Straight Runways

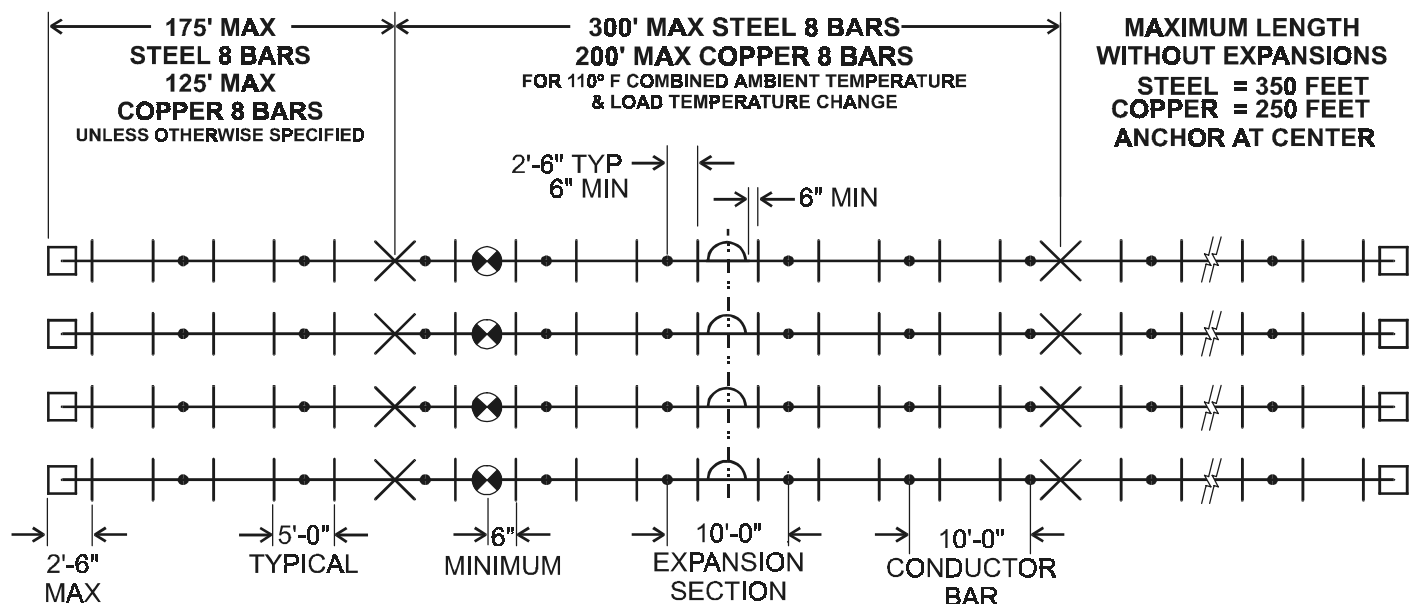

THIS INFORMATION APPLIES ONLY TO STRAIGHT BOTTOM ENTRY RUNWAY INSTALLATIONS OF CONDUCTOR BAR. INSTALLATIONS THAT INCLUDE CURVED SECTIONS REQUIRE SPECIAL CONSIDERATION. PLEASE CONTACT THE FACTORY FOR ASSISTANCE.

END COVER		HANGER		POWERFEED	
EXPANSION SECTION		ANCHOR POINT		SPLICE JOINT	

### III. Typical Collector Mounting Standard Vertical Mount

#### "C" Base, Standard Mount

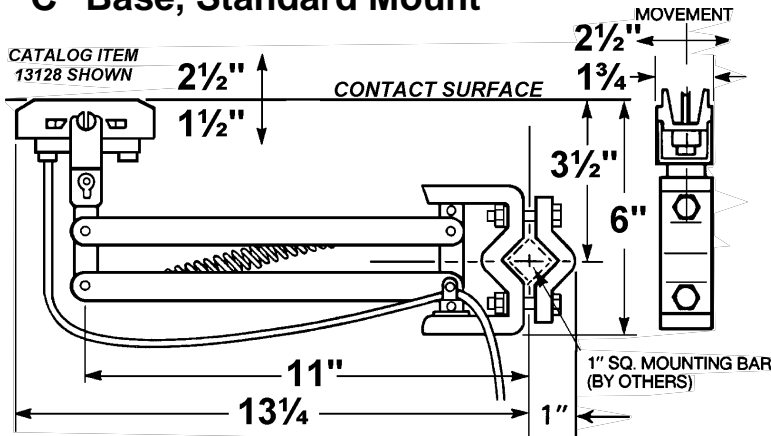

#### "H" Base, Standard Mount

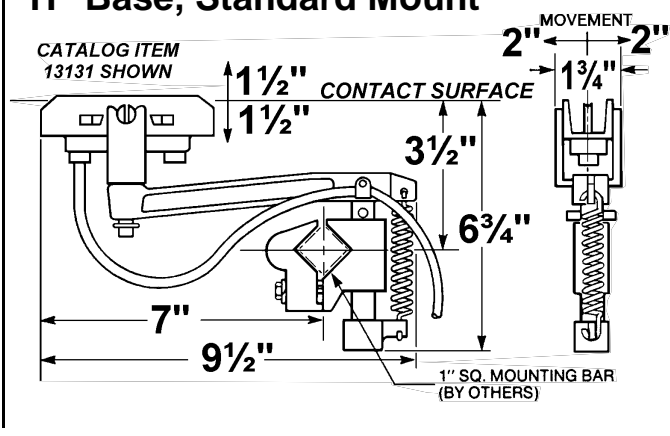

#### "C" Base, Tandem Mount

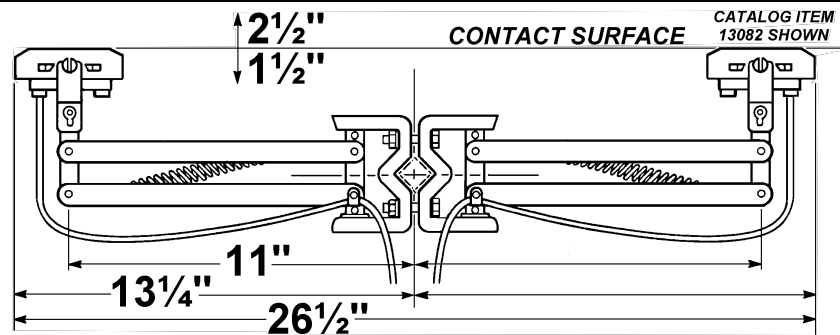

### IV. Typical Expansion Gap & Anchoring Requirements

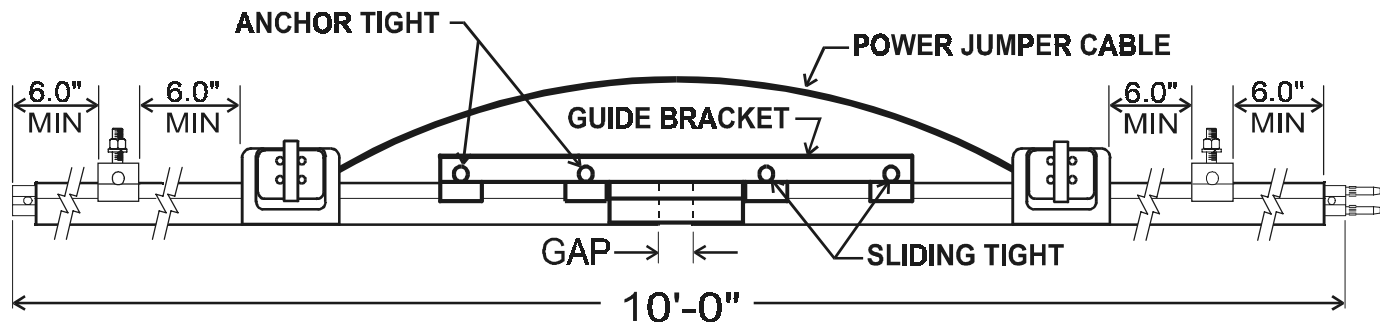

#### Installation of Expansion Sections.

Expansion Sections are installed in the same manner as standard 10' Sections of Conductor Bar. See Step 2.

Expansion Sections are shipped with all four guide bracket clamps secured anchor tight. After the expansion section has been installed, loosen two of the clamp bolts on one side of the guide bracket. Set the expansion gap according to the table below. Then re-tighten the two clamp bolts to anchor tight. Proceed with installation of the remaining conductor bars.

**Important:** After all conductor bars have been installed, loosen the two clamp bolts on one side of the guide bracket on all expansion sections to sliding tight. Recheck the expansion gap after installation and adjust if necessary.

## Expansion & Anchor Location Diagram

Location of expansion sections is critical for proper functioning of the system. Follow installation drawing or, if no drawing is available, refer to above diagram.

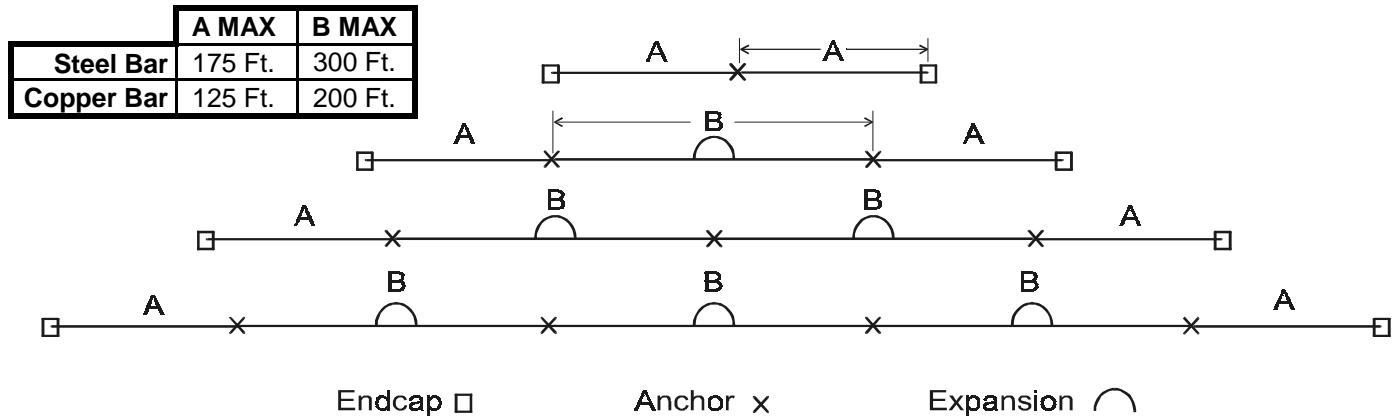

Expansion Gap Settings Table															
Ambient Temp Range (°F)	0°-100°F					20°-120°F					40°-140°F				
Ambient Temp (°F)	0	25	50	75	100	20	45	70	95	120	40	65	90	115	140
Gap Setting (in)	2.50	2.34	2.18	2.02	1.86	2.50	2.34	2.18	2.02	1.86	2.50	2.34	2.18	2.02	1.86

## Anchors

Anchor points are required at midpoint on all systems without expansion sections. For systems with expansion sections, anchors are required midpoint between expansions and between the first and last expansions and the ends of the run, as shown in above diagram.

Cross-Bolt hangers can be used as anchors on systems without expansion sections. See Section V, Step 2 for appropriate torque values. On systems with expansion sections it is recommended that anchor clamps be used. Proper torque for anchor clamp cross bolts is 2-4 ft-lbs.

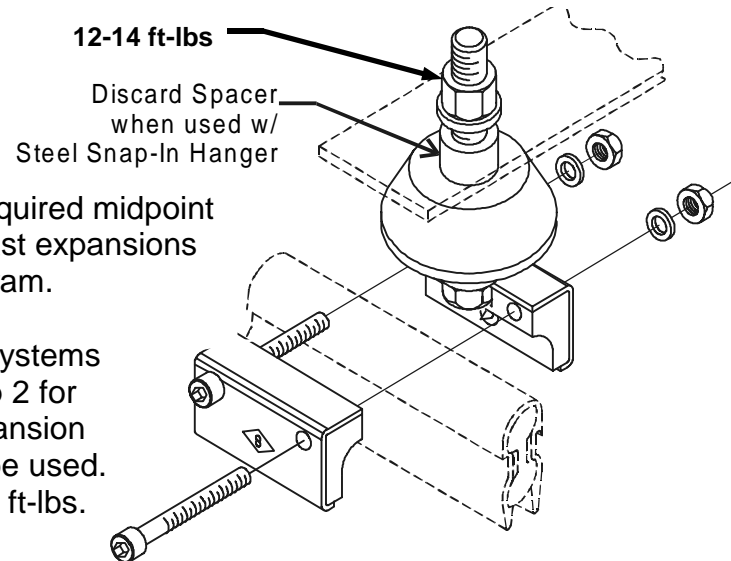

## V. Installation Procedure

### Step 1

Install Hanger & Anchor Clamps as required.

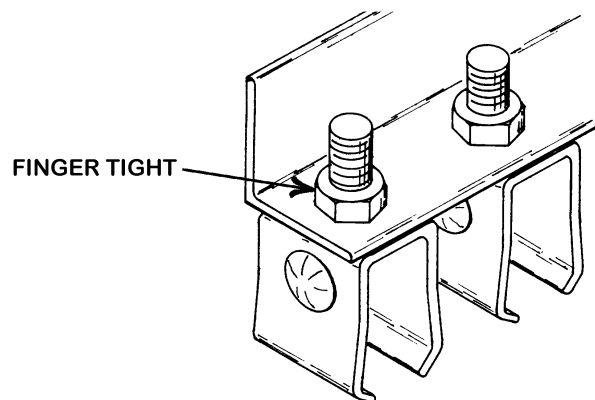

## Step 2 Install Conductor Bar

Note: For Expansion Section Installation Refer to Section IV.

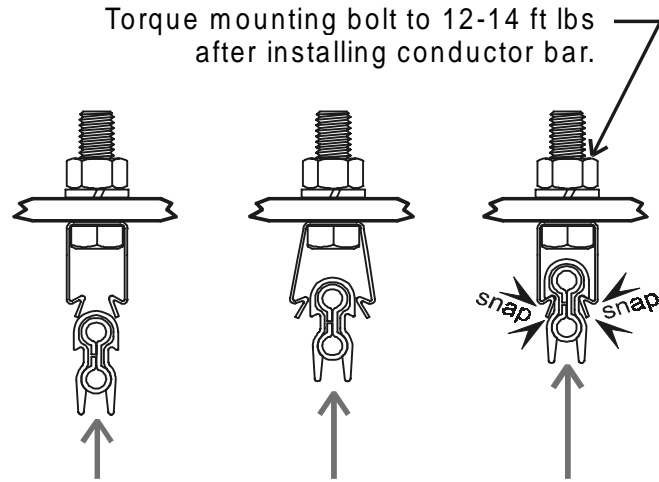

**Steel Snap-In Hangers**

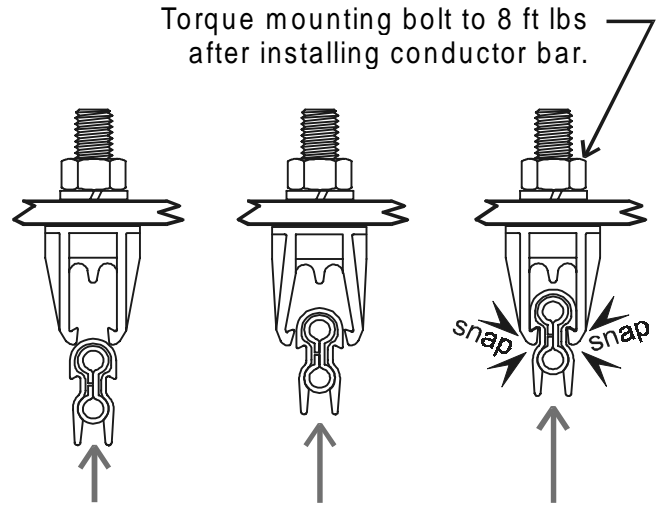

**Plastic Snap-In Hangers**

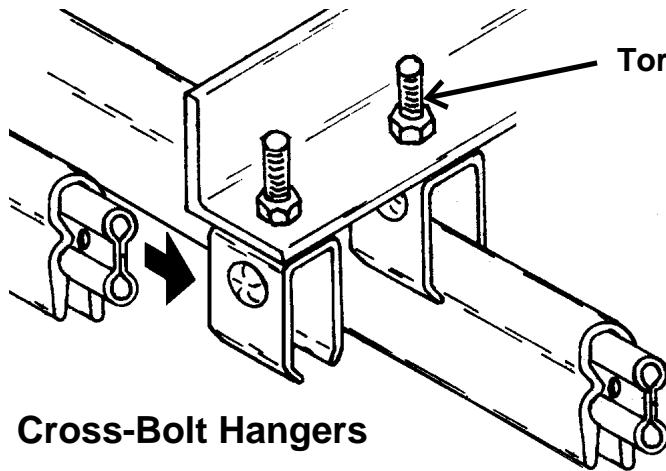

**Cross-Bolt Hangers**

Torque mounting bolt to 12-14 ft-lbs after installing all conductor bar.

### Cross-Bolt Hanger Torque Specs

Hanger Material	Part No.	Sliding Tight	Anchor Tight
Plated Steel	11076	2.5 ft-lbs	4.0 - 5.0 ft-lbs
Stainless Steel	11078	1.5 ft-lbs	3.0 - 4.0 ft-lbs

Sliding Torque specified in the table is not to be exceeded.  
Anchor Torque should fall within the range specified.

## Step 3 Join Conductor Bar

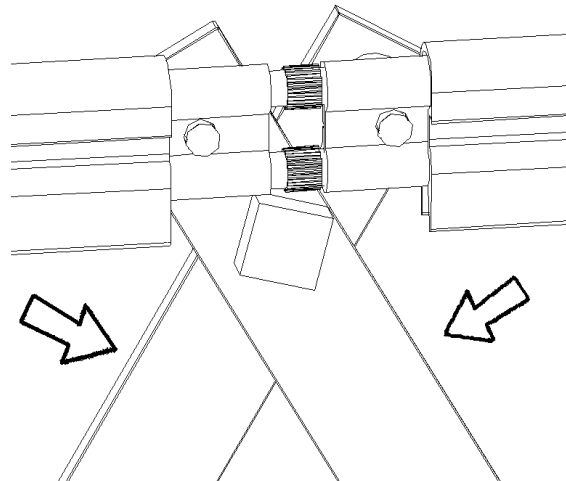

**3a. Joining Pinned Conductors.**

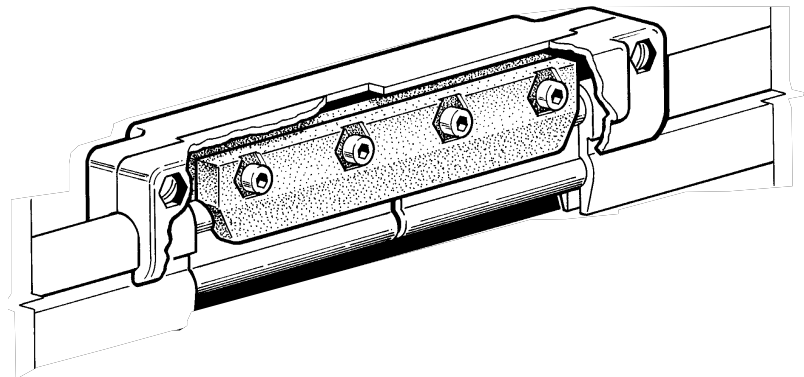

**3b. Joining Bolted Conductors.  
(500 Amp Solid Copper Conductors.)**

## Step 4 Install Joint Keepers

Only Copper Bars require Joint Keepers.

Slide the long end of the joint keeper under the conductor bar cover on the smooth side of the bar.

Push the pins into the holes of the bar.

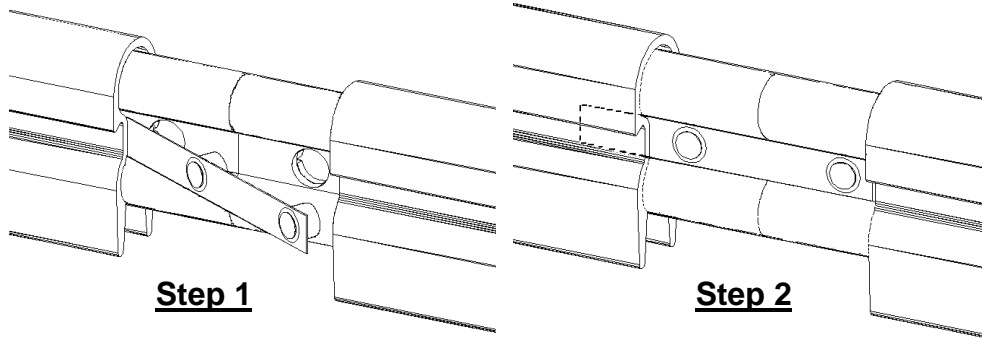

## Step 5 Install Joint Covers

Snap Joint Cover over all Insul-8-Bar joints.

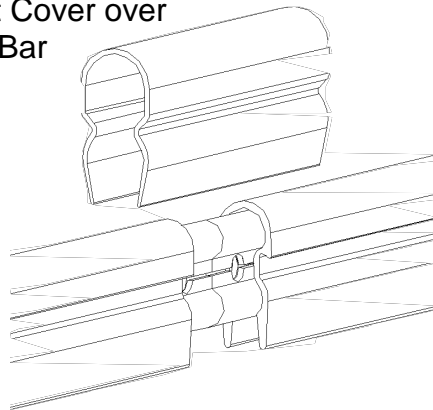

If you have High Heat Joint Cover (P/N 11123):

First snap 4-1/2" cover over exposed conductor.

Then snap on 6" cover and center it over the joint.

Complete the joint cover by clamping both covers in place with the provided cross-bolt clamp.

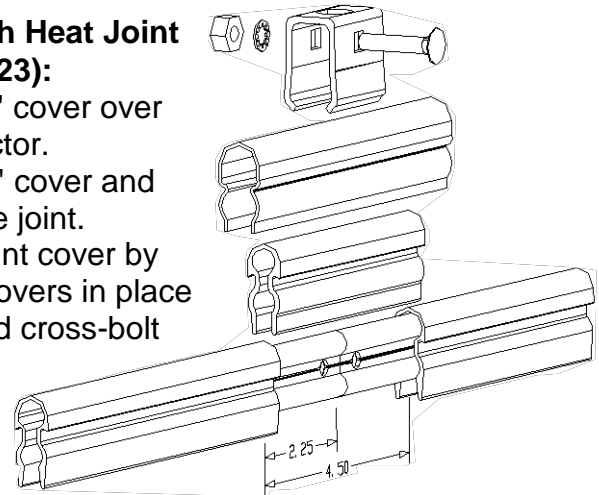

## Step 6 Install Powerfeeds

Install Powerfeeds at locations shown on installation drawing. If no drawing was provided, locate powerfeeds following the designated space considerations as shown. Cut conductor bar cover as shown.

When using large cables, be sure that the customer supplied connector is attached to the clamp in such a manner that it does not interfere with the powerfeed case.

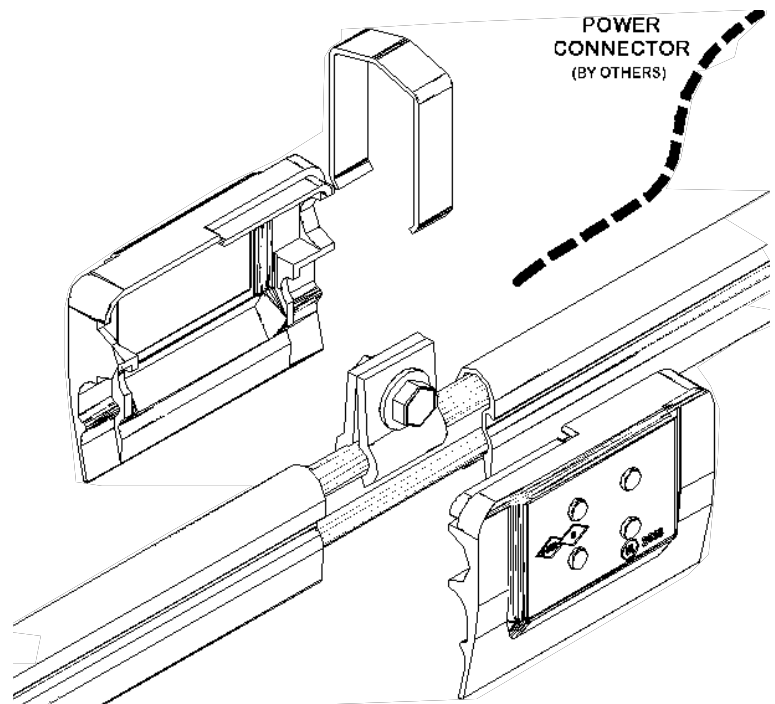
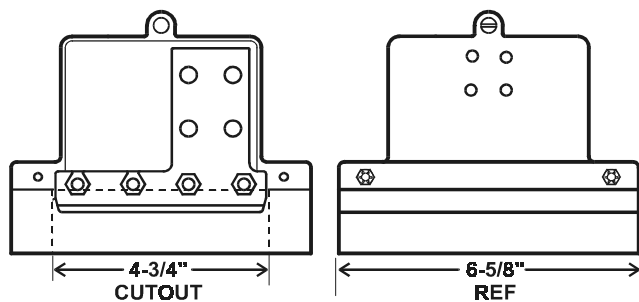
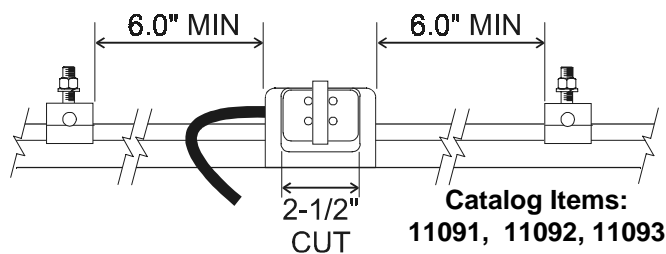

---

**Step 6**  
**Install End Covers / Transfer Caps**

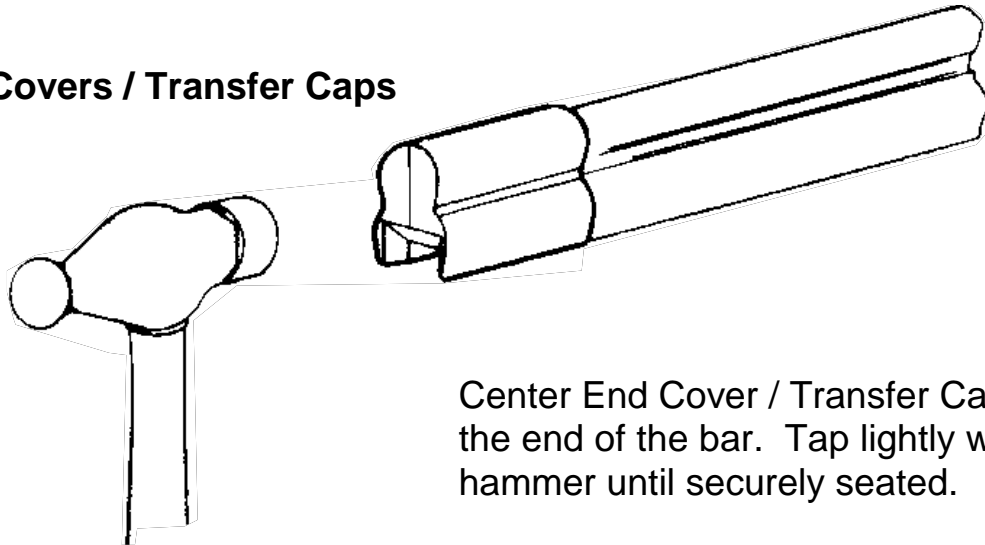

Center End Cover / Transfer Cap on the end of the bar. Tap lightly with a hammer until securely seated.

---

**Step 7**  
**Install Collectors - Refer to Installation Dimensions in Section III.**

---

**Step 8 Final Inspection**

- 1) Sight down the installed conductor runs and straighten any areas where conductor bar is out of alignment. Verify all mounting bolts on hangers are torqued to their proper values.
- 2) Make sure collectors are aligned properly with the conductor bar.
- 3) Check the distance between the centerline of 1" square bar collector mounting staff and contact surface of conductor bar. Distance should be 3-1/2".
- 4) Make sure anchor clamps are properly positioned and anchor tight.
- 5) Make sure clamps on one side of expansion section have been made sliding tight. Verify that the expansion section air gap is correct for the ambient bar temperature.
- 6) Make sure all joint covers and, if applicable, all joint keepers are securely in place.
- 7) Check all electrical connections.
- 8) Prior to introducing the system to service run the application at slow speed through the entire runway length in both directions to verify operation. This will also allow you to identify any potential obstacles that were overlooked during installation. Pay special attention to Collector Arm movements. The alignment of collector to collector (phase to phase) should be relatively uniform.

# Special Applications

## A. Field Cutting

- 1) Cut conductor with a hack saw to desired length
- 2) Cut Cover:
  - PVC Cover: 0.75" shorter than conductor bar.
  - Hi-Heat Cover: 2.25" shorter than conductor bar.
- 3) Deburr/File field cut end as necessary.
- 4) Ream Conductor Lobes:
  - 40, 110-350 Amp Bar: "D" Size Drill Bit
  - 90 Amp Bar: "M" Size Drill Bit
- 5) Install as usual.

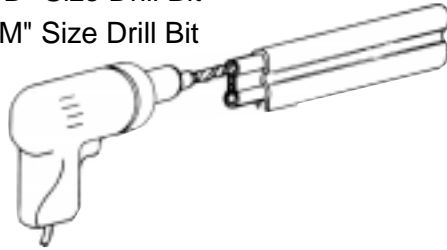

## B. Curves

- 1) Install curved sections of conductor bar before any straight sections.
- 2) Maximum Hanger Spacing on curves is 3'.
- 3) Curves are generally anchored at the apex, at midway between the straight sections. Contact the factory with specific application questions for further information.
- 4) Minimum conductor bar spacing is 2" on curves, 3" recommended.
- 5) Cross Bolt Hanger Clamps must be used on all curves.

## C. Discontinuous Systems

Cross-Bolt Hanger clamps on Pickup Guide Assemblies are required to be anchor tight.

Notes:

1. Pickup Guides must be mounted on 2 hanger supports.
2. Collectors should not be used to interrupt current.

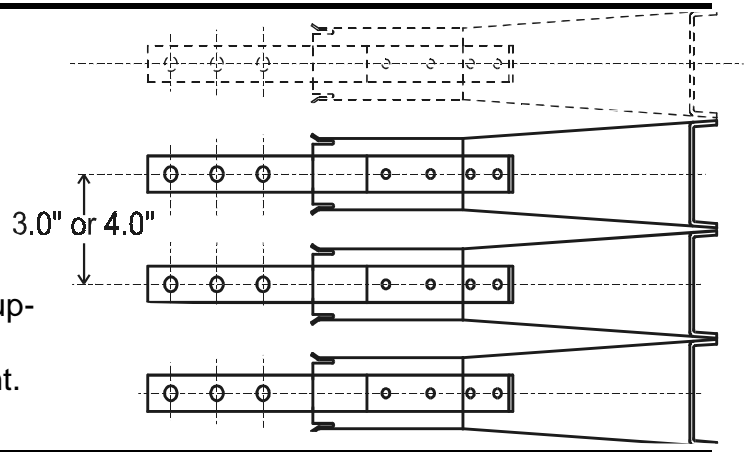

## D. Interlock, Switches, or Fixed Gaps.

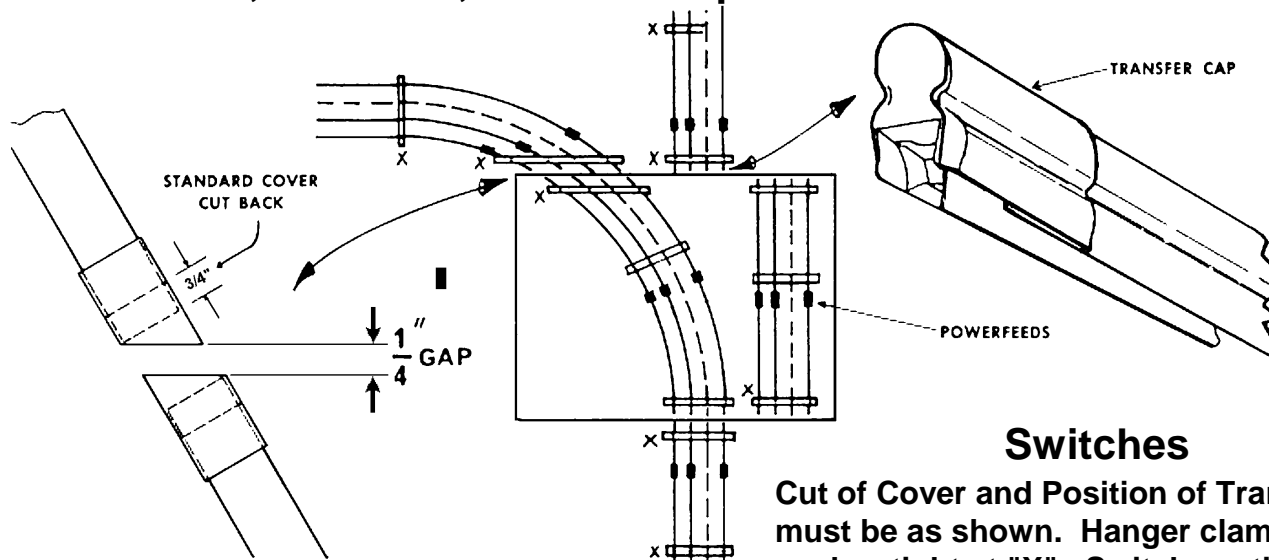

### Switches

Cut of Cover and Position of Transfer Cap must be as shown. Hanger clamps to be anchor tight at "X". Switch sections over 25' may require an expansion section.

## E. Laterally Mounted Systems. Contact the factory: 800-521-4888

## TROUBLESHOOTING

Properly installed and normally inspected rigid conductor systems very seldom require extensive maintenance. When properly installed, shoe inspection and replacement is usually all that is necessary. The following table can be used as a normal maintenance check list, as well as a troubleshooting list.

8-Bar Conductor Troubleshooting		
Problem	Probable Cause	Solution
Burned joints or burned cover at joints.	Loose joint, excess vibration, or over-tightened hanger clamps. Joint Keeper not used.	Tighten joint, install joint keeper, check hanger clamps, & replace joint cover.
Distorted cover.	Too high ambient temperature, under-rated bar.	Use high or medium heat cover. Check total current draw under worst conditions.
Pitted or burned conductor.	Improper shoe pressure or worn out shoe.	Check collector mounting and spring pressure. Check for worn out shoe. If the above are corrected & condition persists, install tandem collectors.
Damaging environment.	Acid fumes, salt air, extremely dirty atmosphere.	May require copper or stainless steel conductor. Under these conditions conductor should always be mounted for vertical entry.

8-Bar Collector Troubleshooting		
Problem	Probable Cause	Solution
Shoes wearing unevenly	Collector not mounted directly under conductor. Square bar is rotated out of square.	Remount or adjust collector.
	Lead wire not slacked.	Loosen lead wire.
	Collector movement too tight.	Free collector movement & lubricate.
Shoes pitted or burned	Insufficient shoe pressure. Excessive bouncing or hand-pulled trolley not stable.	Check shoe pressure and mounting distance. Excessive bouncing can be reduced with tandem collectors. Install guide rollers on hand pulled trolleys. Also see: Pitted or burned conductor.
De-tracking.	Distorted cover or joint cover.	Check condition, replace as necessary.
	Misalignment at switches or crossovers.	Re-align and re-anchor. Check switch movement.
	Improperly installed.	Correct misalignment. Bad misalignment may require long arm collectors or expansion sections.
	Hanger clamp (cross-bolt type) too tight making bar "snake" to where collectors interfere with each other.	Loosen hangers so bar will slide. Tighten one hanger in center or between each expansion section.

### Replacement Parts

The following is a suggested list of maintenance parts for use in the field:

- > One extra set of contact shoes for each collector.
- > One extra spring for each collector.

- > Six extra lengths of bar or 5% of total footage for average sized installations.
- > One clamp connector and cover for each extra length of bar where clamp replacement is desirable.
- > Three complete collectors for 3 phase system, where use is severe.



10102 F Street • Omaha, NE 68127 • USA

**USA:** FAX To: (402) 339-9627 (24 HRS)  
 Voice Verify: (800) 521-4888 (Central)

---

**Canada:** FAX To: (450) 432-6985 (24 HRS)  
 Voice Verify: (800) 667-2487 (Eastern)